

**CHL** Light Horizontal  
Multistage Centrifugal Pump

---

50Hz

2006

PUMPS



## GENERAL DATA

Performance scope.....	3
Curve conditions.....	3
Application.....	4
Applicable medium.....	4
Operation condition.....	4
Pump.....	4
Definition of Model.....	5
Electric Motor.....	5
Material CHL,CHLK2,4,8,16.....	6
Material CHLF,CHLF(T)2,4.....	6

## TECHNICAL DATA

CHL,CHLK2.....	9
CHL,CHLK4.....	10
CHL,CHLK8.....	11
CHL,CHLK16.....	12
CHLF,CHLF(T)2.....	13
CHLF,CHLF(T)4.....	14
CHLF,CHLF(T)8.....	15

**Performance scope**

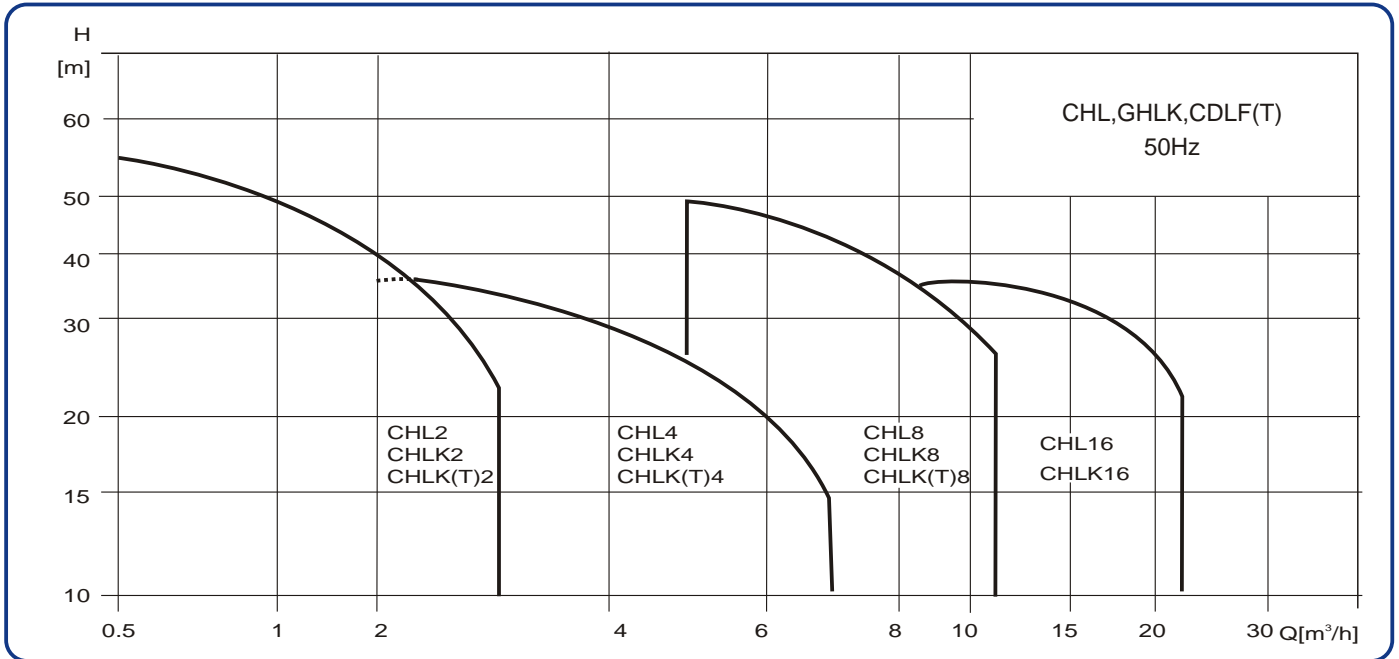

**Curve conditions**

Following conditions are suitable for the performance curves shown above

- All the performance curves are based on the measured values of a motor 3×380V~415V at a constant speed of 2900 rpm.
- Curve tolerance in conformity with ISO9906, appendix A
- Measurement is done with 20°C air-free water, kinematic viscosity of 1mm²/sec;
- The operation of pump shall refer to the performance region described by the thickened curve to prevent overheating due to too small flow rate or overload of motor due to too large flow rate.

## Application

CHL,CHLK and CHLF(T) type pump are mainly used in industrial field:

- Air-conditioning system
- Cooling system
- Industrial cleaning
- Water treatment (water Purification)
- Aquiculture
- Fertilizing/metering system
- Environmental application
- Other special applications

## Applicable Medium

- Thin and clean non-flammable and non-explosive liquid without solid granules and fibers.
- Mineral water, soft water, pure water, edible vegetable oil and other light chemical mediums.
- When the density or viscosity of to-be-conveyed liquid is larger than that of water, it is necessary to select a driving motor of high power.
- Whether a specific liquid is suitable for the pump depends on many factors, among which the most important ones are chlorine content, PH value, temperature, solvent and oil content.

## Operation condition

- Liquid temperature:
- Normal temperature type:  $-15^{\circ}\text{C} \sim +70^{\circ}\text{C}$
- Hot water type:  $+70^{\circ}\text{C} \sim +110^{\circ}\text{C}$
- Highest ambient temperature:  $+40^{\circ}\text{C}$
- Max. operation pressure: 10 bar
- Max. inlet pressure is limited by max. operation pressure

## Pump

- Horizontal multistage non-self-priming centrifugal pump, attached with long shaft electric motor.
- Compact structure renders small size of pump: axial inlet and radial outlet.

Connection port	CHL,CHLK,CHLF(T)2	CHL,CHLK,CHLF(T)4	CHL,CHLK8,16	CHLF(T)8
Inlet	G1	G1 $\frac{1}{4}$	G1	G1 $\frac{1}{2}$
Outlet	G1	G1	G1	G1 $\frac{1}{4}$

## Definition of Model

CHL Example

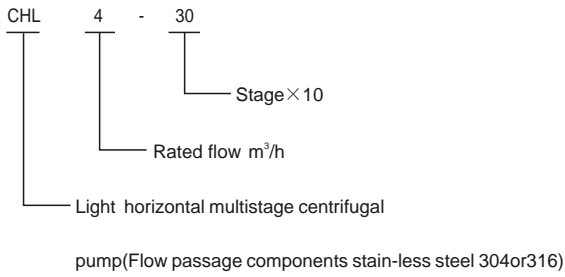

CHLK Example

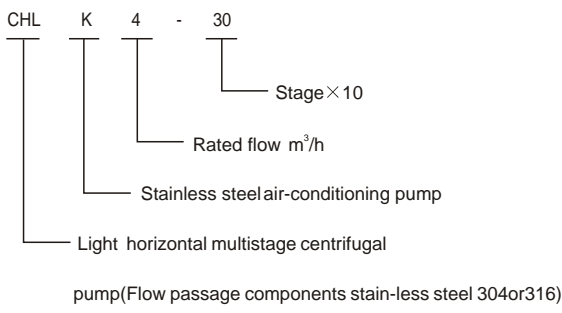

CHLF(T) Example

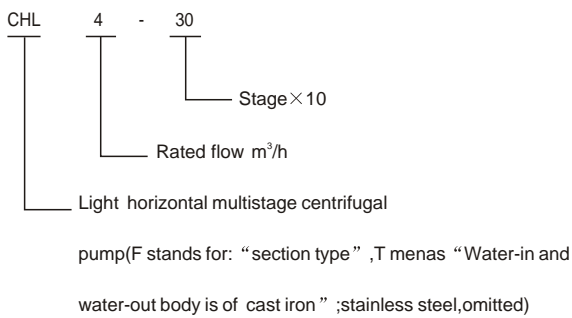

## Electric Motor

- Full-enclos, air-blast two-pole motor
- Protection class: IP55
- Insulation class: F
- Standard voltage, 50Hz: 1x220-240V

3x220-240V/380-415V

**Material CHL,CHLK2, 4, 8, 16**

No	Name	Material	AISI/ASTM
1	Inlet and outlet section	Stainless steel	AISI304
2	Connection pipe	Stainless steel	AISI304
3	Clamp plate	Stainless steel	AISI304
4	Impeller	Stainless steel	AISI304
5	Shaft	Stainless steel	AISI304
6	Gag	Stainless steel	AISI304
7	Water-out guide vane	Stainless steel	AISI304
8	Mechanical seal		
9	Motor end cover	Aluminum alloy	
10	Base frame	Cast iron	ASTM25B
11	Quick joint	Stainless steel	AISI304
12	Guide vane	Stainless steel	AISI304
13	Support guide vane	Stainless steel	AISI304
14	Inducer	Stainless steel	AISI304

**Material CHLF, CHLF(T)8**

No	Name	Material	AISI/ ASTM
2	Gag	Stainless steel	AISI304
3	Bearing	Tungsten carbide	
4	Impeller	Stainless steel	AISI304
5	Shaft	Stainless steel	AISI304
6	Water-out guide vane	Stainless steel	AISI304
8	Mechanical seal		
9	Motor end cover	Aluminum alloy	
10	Base frame	Cast iron	ASTM25B
11	Pull-rod	Stainless steel	AISI304
12	Guide vane	Stainless steel	AISI304
13	Support guide vane	Stainless steel	AISI304
14	Impeller separating sleeve	Stainless steel	AISI304
<b>CHLF</b>			
1	Water-in body	Stainless steel	AISI304
7	Water-out body	Stainless steel	AISI304
<b>CHLF (T)</b>			
1	Water-in-body	Cast iron	ASTM25B
7	Water-out body	Cast iron	ASTM25B

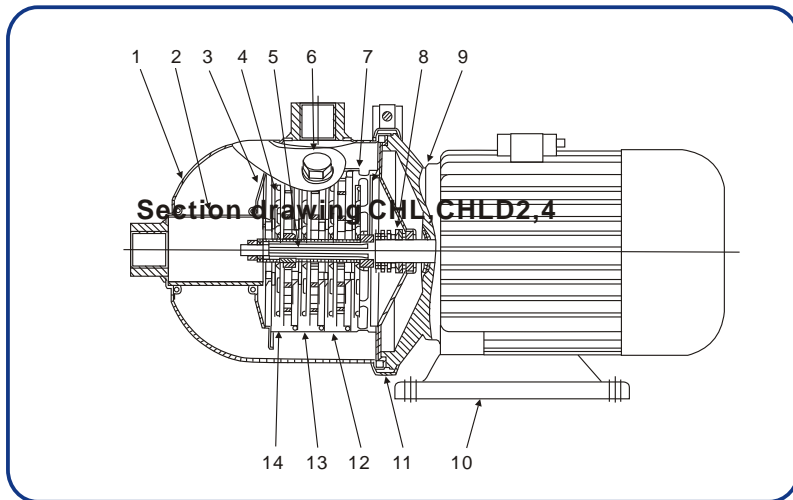

**Section drawing CHL, CHLK8,16**

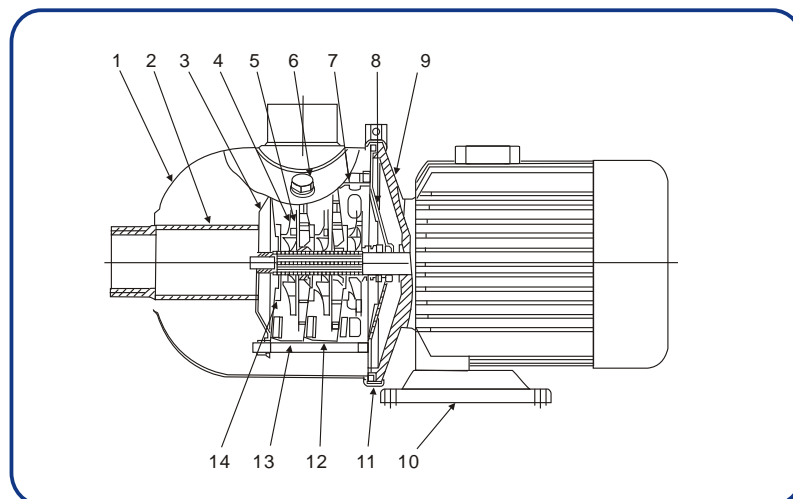

**Section drawing CHLF, CHLF(T)8**

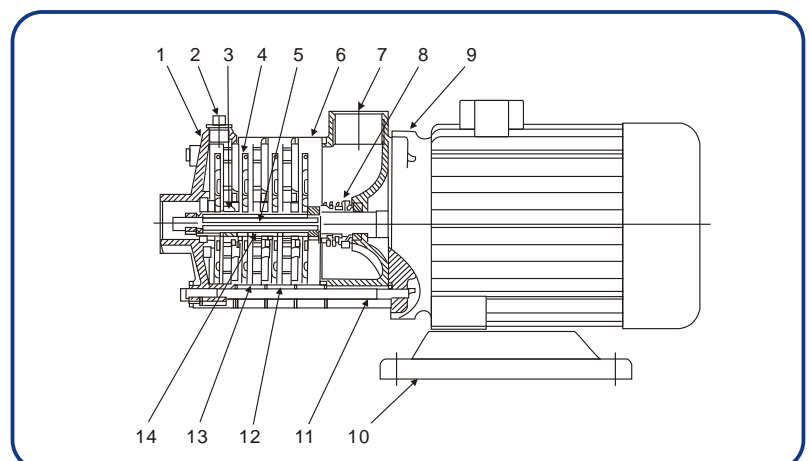

Section drawing CHLF,CHLF(T)2,4

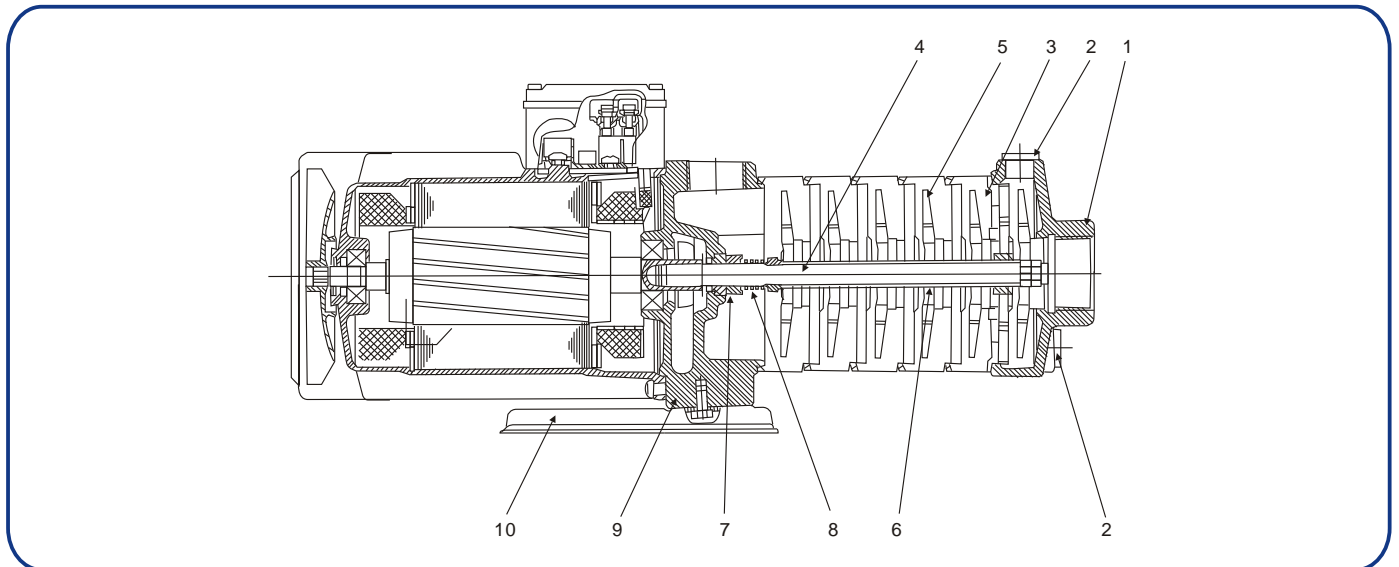

Materials, CHLF(T)2,4

Position	Pump component	Material	DIN/EN
1	Suction chamber	Cast iron	EN-JL1030
2	Drain plug, priming plug	Steel	1.0718
3	Chamber	Stainless steel	1.4301
4	Pump shaft	Stainless steel	1.4057/1.4401
5	Impeller	Stainless steel	1.4301
6	Spacing pipe	Stainless steel	1.4301/1.4305
7	Shaft seal faces	Carbon/ceramics	
8	Spring	Stainless steel	1.4310
9	Discharge chamber	Cast iron	EN-JL1030
10	Base plate	Painted steel	10330.3
	O-rings	FKM	

Materials,CHLF2,4

Position	Pump component	Material	DIN/EN
1	Suction chamber	Cast stainless steel	1.4308
2	Drain plug, priming plug	Stainless steel	1.4301
3	Chamber	Stainless steel	1.4301
4	Pump shaft	Stainless steel	1.4057
5	Impeller	Stainless steel	1.4301
6	Spacing pipe	Stainless steel	1.4301/1.4305
7	Shaft seal faces	Carbon/ceramics	
8	Spring	Stainless steel	1.4310
9	Discharge chamber	Cast stainless steel	1.4308
10	Base plate	Stainless steel	1.4301
	O-rings	FKM	

### Performance curve

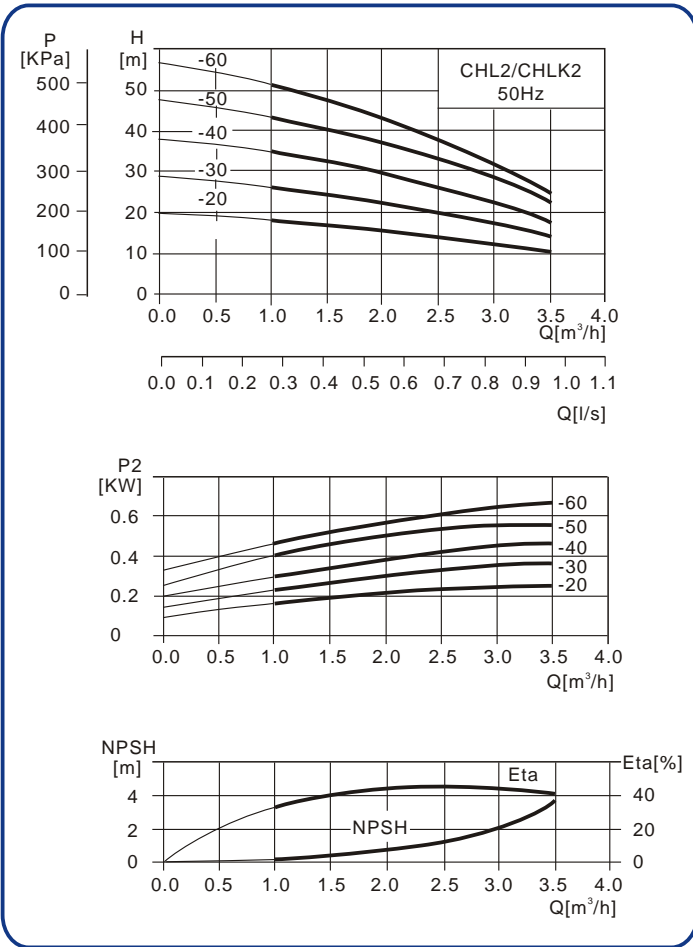

## CHL, CHLK2

### Installation sketch

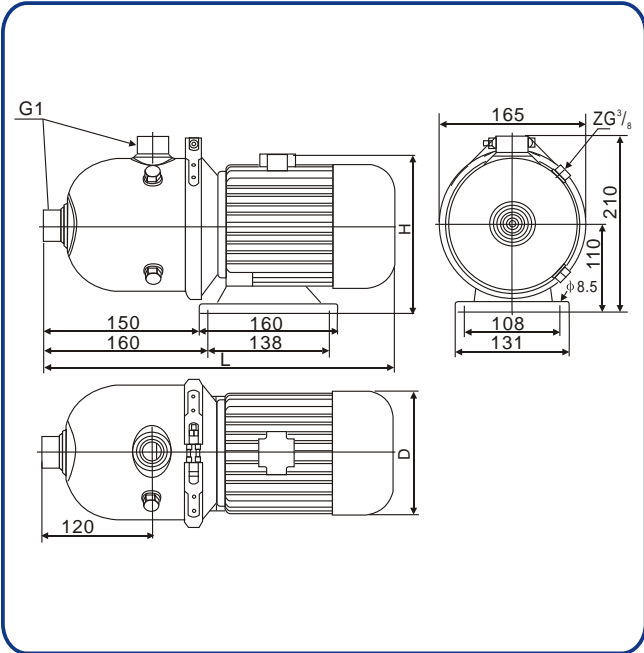

### Size and weight

Model	L(mm)	D(mm)	Weight/(kg)
CHL2-20	400	145	10
CHL2-30	400	145	10
CHL2-40	400	145	10
CHL2-50	400	145	10
CHL2-60	445	170	10

### Performance table

Model	Driving motor (KW)	Q (M³/h)	H (m)						
			0.5	1.0	1.5	2.0	2.5	3.0	3.5
CHL2-20	0.37	H (m)	19	18	16	14	13	11	9
CHL2-30	0.55		28	27	24	21	20	17	14
CHL2-40	0.55		36	34	32	28	26	23	17
CHL2-50	0.55		46	43	40	35	33	28	22
CHL2-60	0.75		54	50	48	42	38	33	25

Performance curve

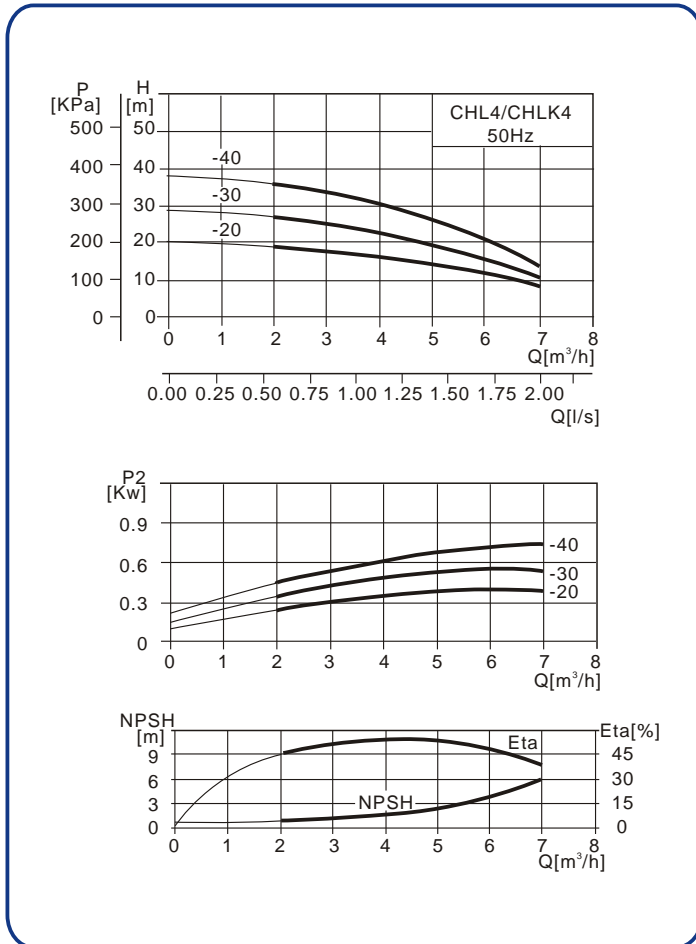

**CHL,CHLK4**

Installation sketch

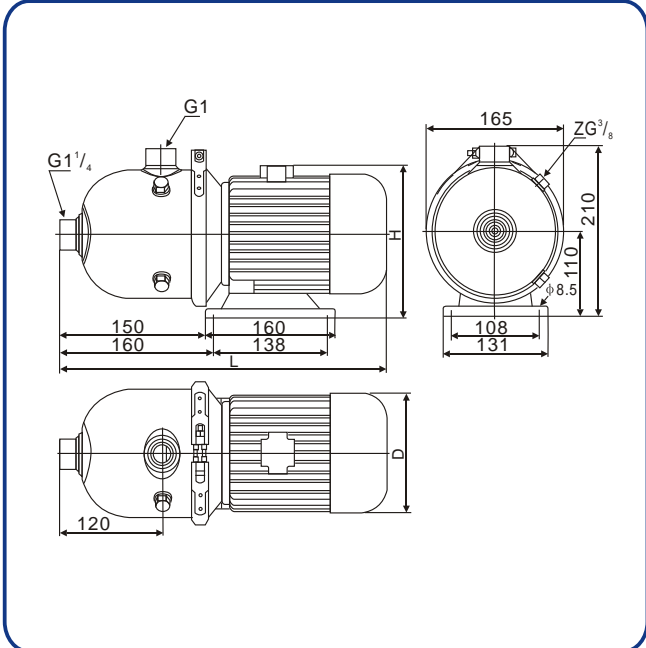

Size and weight

Model	L(mm)	D(mm)	Weight/(kg)
CHL4-20	400	145	10
CHL4-30	445	170	10
CHL4-40	445	170	10

Performance table

Model	Driving motor (KW)	Q (M³/h)	H (m)						
			1	2	3	4	5	6	7
CHL4-20	0.55	H (m)	19	18	16	15	13	10	7
CHL4-30	0.75		28	27	24	22	19	15	10
CHL4-40	0.75		38	36	32	30	26	20	14

### Performance curve

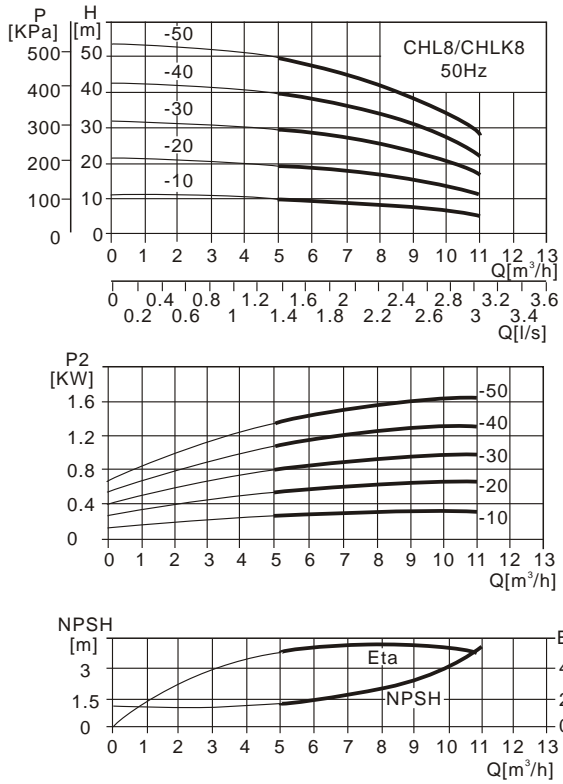

## CHL,CHLK8

### Installation sketch

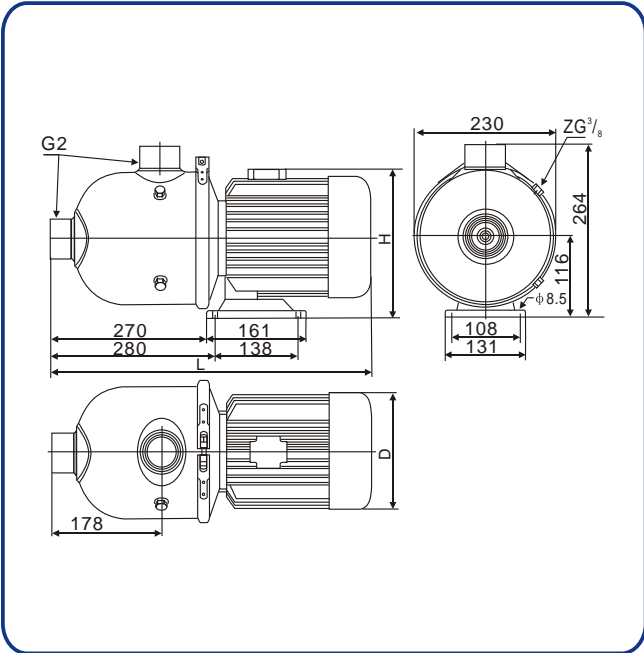

### Size and weight

Model	L(mm)	H(mm)	D(mm)	Weight/(kg)
CHL8-10	540	220	170	20
CHL8-20	540	220	170	20
CHL8-30	550	220	170	25
CHL8-40	560	230	180	25
CHL8-50	570	230	180	30

### Performance table

Model	Driving motor (KW)	Q (M³/h)	H (m)						
			5	6	7	8	9	10	11
CHL8-10	0.75	H (m)	9.5	9.3	9	8.5	7.5	6.5	5.5
CHL8-20	0.75		19	18.5	18	17	15	13	11
CHL8-30	1.1		29	28	27	25.5	22.5	20	17.5
CHL8-40	1.5		39	38	36	34	30	26.5	22.5
CHL8-50	2.2		49	47	45	42.5	38	33.5	28

Performance curve

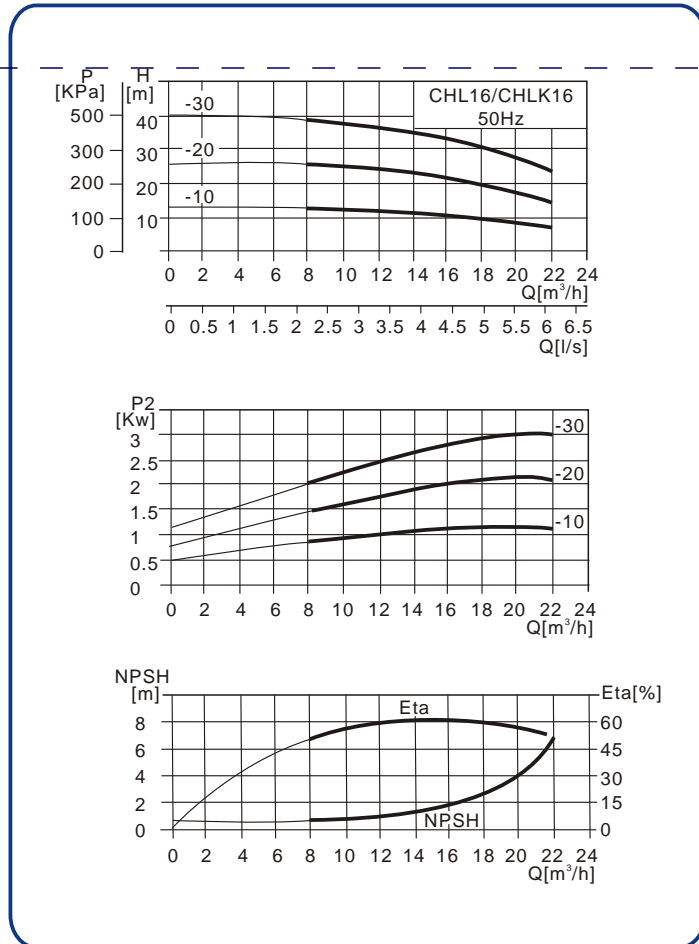

**CHL,CHLK16**

Installation sketch

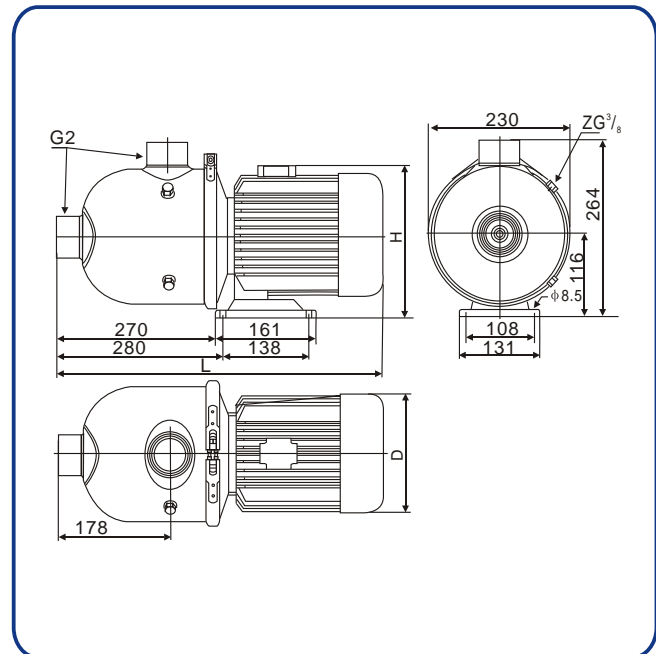

Size and weight

Model	L(mm)	H(mm)	D(mm)	Weight/(kg)
CHL16-10	560	220	170	20
CHL16-20	570	230	180	25
CHL16-30	590	230	180	30

Performance table

Model	Driving motor (KW)	Q (M³/h)	H (m)							
			8	10	12	14	16	18	20	22
CHL16-10	1.1	H (m)	12.5	12	11.5	10.5	10	9	7.5	6.5
CHL16-20	2.2		25.5	24	23	22	21	19	17	14.5
CHL16-30	3		38.5	37	36	34	32	30	27	23

## Performance curve

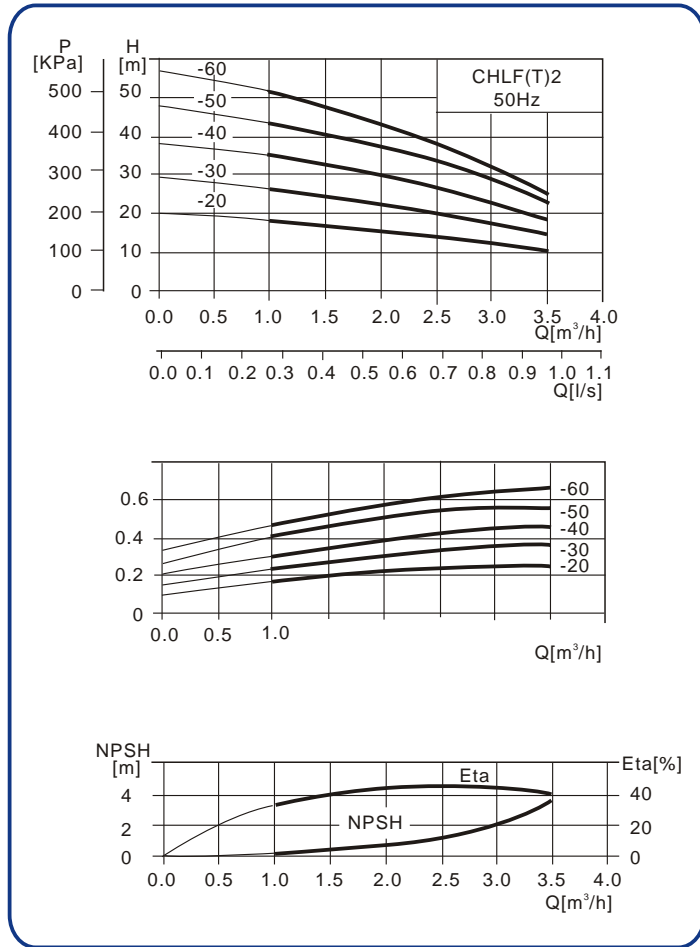

# CHLF, CHLF(T)2

## Installation sketch

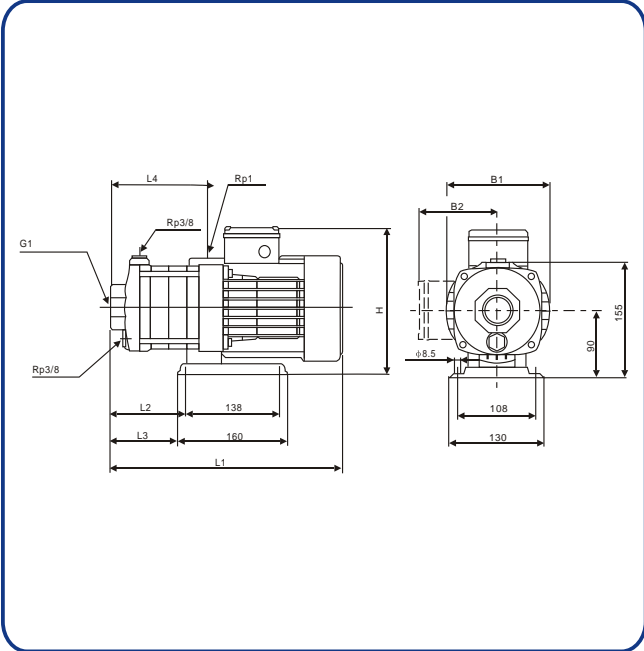

## Size and weight

Pump type	Motor type		L1 [mm]		L2 [mm]	L3 [mm]	L4 [mm]	B1 [mm]	B2 [mm]		H [mm]		Net weight [kg]	
	1-phase	3-phase	1-phase	3-phase					1-phase	3-phase	1-phase	3-phase	1-phase	3-phase
CHLF(T)2-20	MG 71	MG 71	304	304	74	63	99	146	115	110	205	200	9.6	11.1
,CHLF(T)2-30			324	322	92	81	117	146	115	110	205	200	9.6	10.7
CHLF(T)2-40			340	340	110	99	135	146	115	110	205	200	10.9	11.0
CHLF(T)2-50			358	358	128	117	154	146	115	110	205	200	11.3	11.5
CHLF(T)2-60			376	376	146	135	172	146	115	110	205	200	11.6	11.8

## Performance table

Model	Driving motor (KW)	Q (M³/h)	0.5	1.0	1.5	2.0	2.5	3.0	3.5
CHLF(T)2-20	0.37	H (m)	19	18	16	14	13	11	9
CHLF(T)2-30	0.55		28	27	24	21	20	17	14
CHLF(T)2-40	0.55		36	34	32	28	26	23	17
CHLF(T)2-50	0.55		46	43	40	35	33	28	22
CHLF(T)2-60	0.75		54	50	48	42	38	33	25

Performance curve

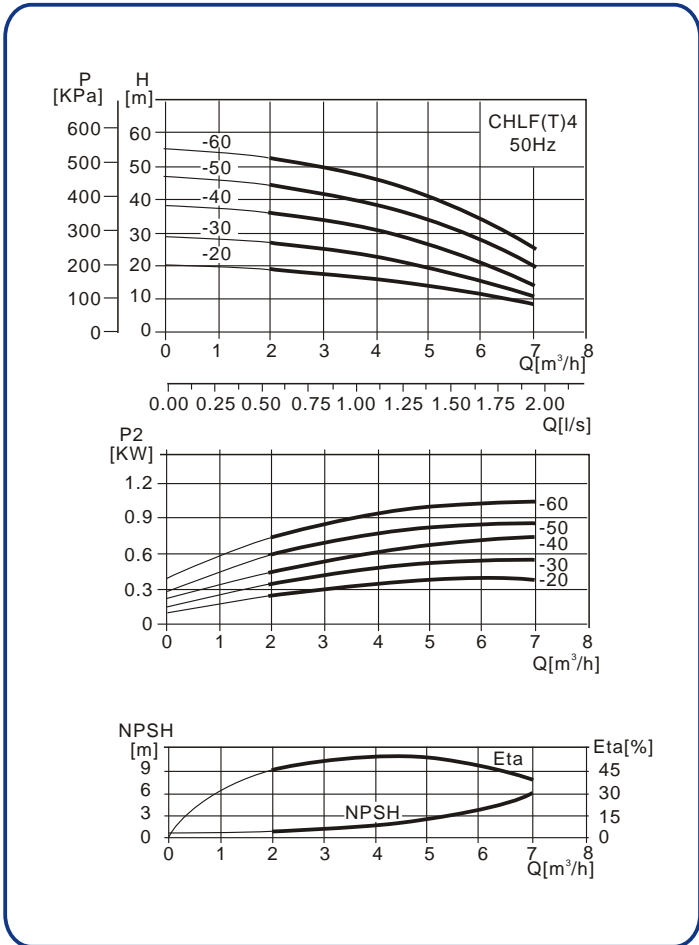

**CHLF,CHLF(T)4**

Installation sketch

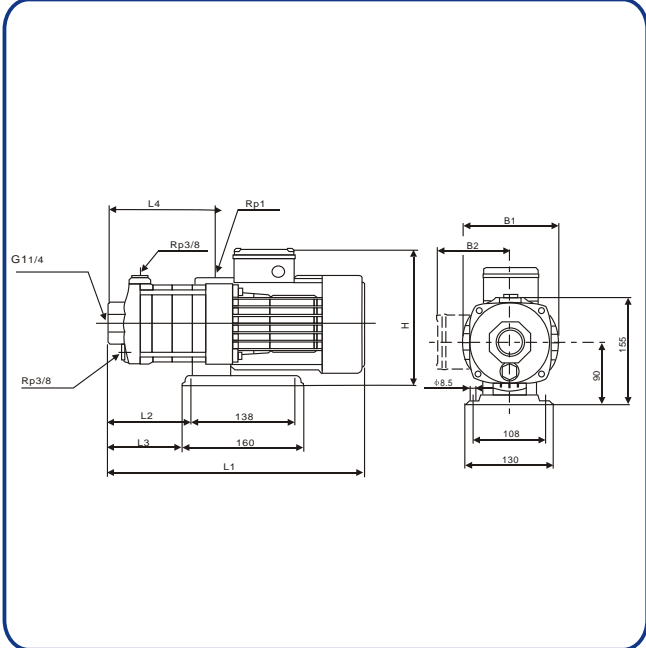

Size and weight

Pump type	Motor type		L1 [mm]		L2 [mm]	L3 [mm]	L4 [mm]	B1 [mm]	B2 [mm]		H [mm]		Net weight [kg]	
	1-phase	3-phase	1-phase	3-phase					1-phase	3-phase	1-phase	3-phase	1-phase	3-phase
CHLF(T)4-20	MG 71	MG 71	314	314	83	72	108	146	115	115	205	200	9.5	9.6
CHLF(T)4-30			342	342	110	99	135	146	110	110	205	200	10.9	11.0
CHLF(T)4-40			370	370	137	126	163	146	110	110	205	200	12.3	12.5
CHLF(T)4-50	MG 80	MG 80	436	438	164	153	190	142	135	110	225	200	16.0	14.2
CHLF(T)4-60			466	466	191	180	217	142	135	110	225	200	15.2	14.9

Performance table

Model	Driving motor (KW)	Q (M³/h)	1	2	3	4	5	6	7
CHLF(T)4-20	0.55	H (m)	19	18	16	15	13	10	7
CHLF(T)4-30	0.55		28	27	24	22	19	15	10
CHLF(T)4-40	0.75		38	36	32	30	26	20	14
CHLF(T)4-50	1.10		46	44	41	38	32	26	20
CHLF(T)4-60	1.10		55	53	50	45	37	31	26

### Performance curve

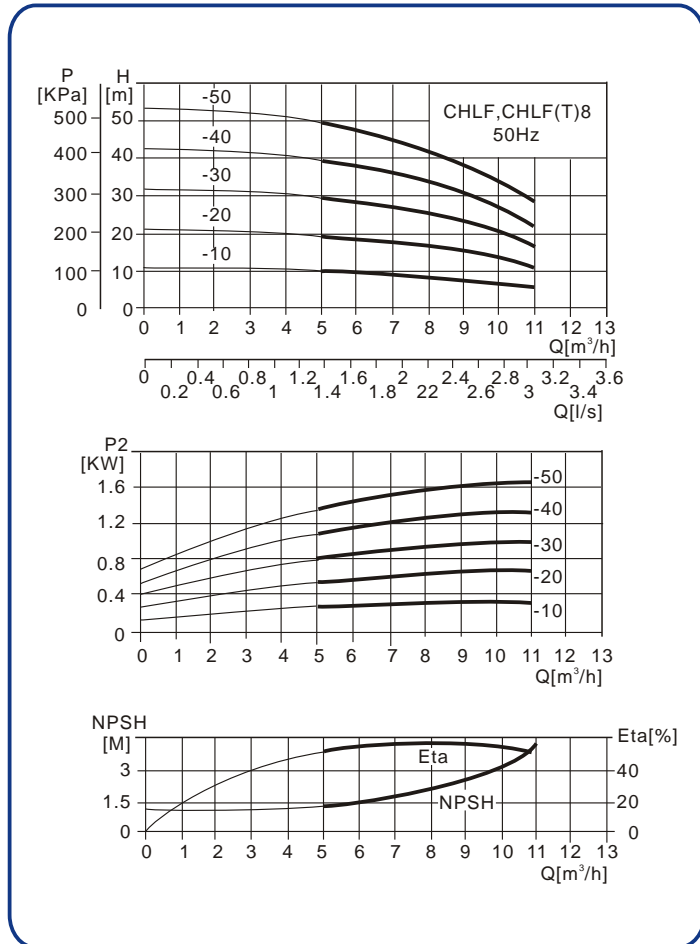

## CHLF, CHLF(T)8

### Installation sketch

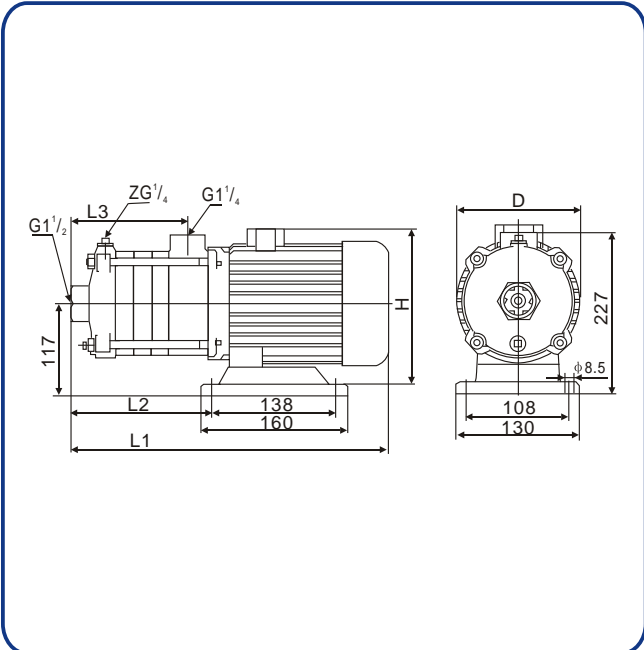

### Size and weight

Model	L1(mm)	L2(mm)	L3(mm)	H(mm)	D(mm)	Weight/(kg)
CHLF(T)8-10	365	98	75	250	170	20
CHLF(T)8-20	395	128	105	250	170	20
CHLF(T)8-30	425	158	135	250	170	25
CHLF(T)8-40	490	188	165	270	180	28
CHLF(T)8-50	520	218	195	270	180	30

### Performance table

Model	Driving motor (KW)	Q (M³/h)	H (m)						
			5	6	7	8	9	10	11
CHLF(T)8-10	0.75	H (m)	9.5	9.3	9	8.5	7.5	6.5	5.5
CHLF(T)8-20	0.75		19	18.5	18	17	15	13	11
CHLF(T)8-30	1.1		29	28	27	25.5	22.5	20	17.5
CHLF(T)8-40	1.5		39	38	36	34	30	26.5	22.5
CHLF(T)8-50	2.2		49	47	45	42.5	38	33.5	28

Note:

**USR<sup>®</sup>**<sub>PUMPS</sub>  
USR Pumps Co  
6-703 Guangyi Street, Fuan City, Fujian,  
China PC.355000  
Tel:+86 593 657 8803 Fax:+86 593 657 8802  
Http:\\www.USRpumps.com  
E-mail:info@USRpumps.com

The technical data are subject to amend without notice.